

L-MOUNT SERIES: L21/L22

Dimensions & Performance Characteristics

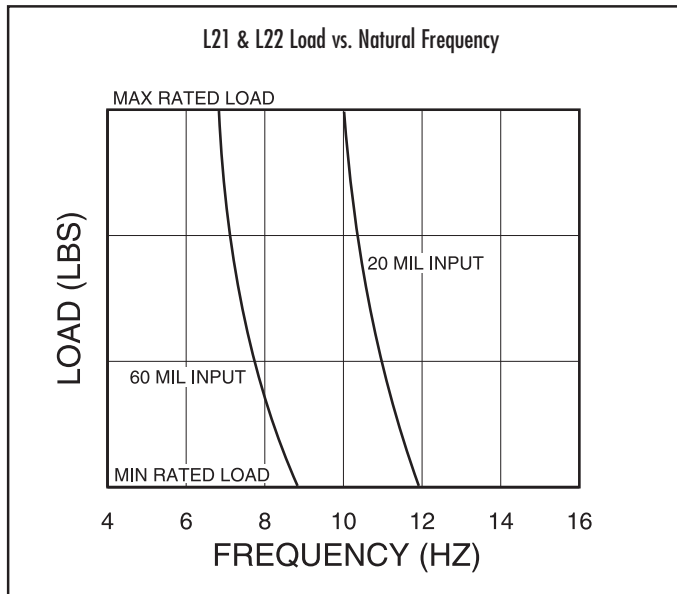
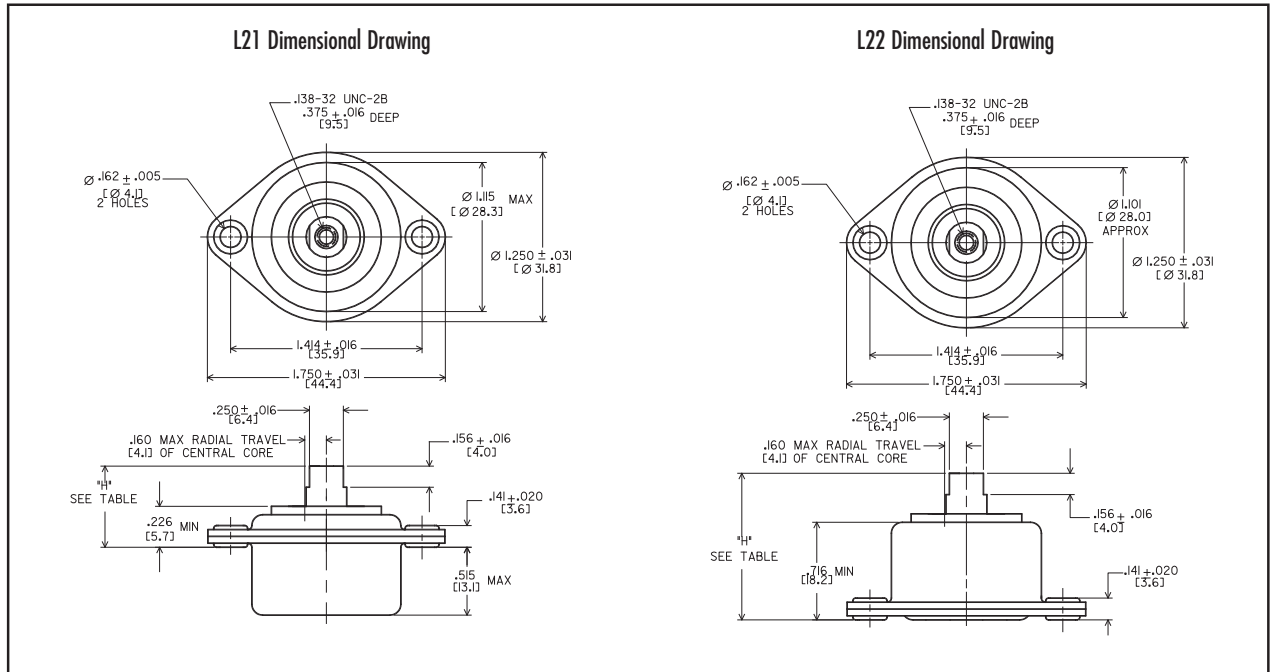

L21-BA MOUNT	
HEIGHT OF ALUMINUM CORE (Inches) ("H")	
Compressed	.219 (min.)
Under min. load	0.50 (approx.)
Extended	.703 (max.)

L22-BA MOUNT	
HEIGHT OF ALUMINUM CORE (Inches) ("H")	
Compressed	.719 (min.)
Under min. load	1.00 (approx.)
Extended	1.172 (max.)